

SPLIT MURAL ARTIC

Serie
SPLIT MURAL ARTIC

Edition
11/25

Models
DS-9KZ DOS-9KZ
DS-12KZ DOS-12KZ
DS-18KZ DOS-18KZ
DS-24KZ DOS-KZ

CONTENTS

SAFETY PRECAUTIONS	1
NAME OF PARTS	4
REMOTE CONTROLLER.....	6
OPERATION INSTRUCTIONS	19
INSTRUCTION FOR SERVICING(R32).....	20
INSTALLATION PRECAUTIONS	25
INDOOR UNIT INSTALLATION	28
OUTDOOR UNIT INSTALLATION	33
TEST OPERATION	37
MAINTENANCE	38
TROUBLESHOOTING	40
DISPOSAL GUIDELINE.....	41
<hr/>	
QUERY MODE.....	47
DRY CONTACT INSTRUCTION.....	48

* The design and specifications are subject to change without prior notice for product improvement. Consult with the sales agency or manufacturer for details.

* The shape and position of buttons and indicators may vary according to the model, but their function are the same.

SAFETY PRECAUTIONS

SAFETY RULES AND RECOMMENDATIONS FOR THE INSTALLER

1. Read this guide before installing and using the appliance.
2. During the installation of the indoor and outdoor units the access to the working area should be forbidden to children. Unforeseeable accidents could happen.
3. Make sure that the base of the outdoor unit is firmly fixed.
4. Check that air cannot enter the refrigerant system and check for refrigerant leaks when turning on the air conditioner.
5. Carry out a test cycle after installing the air conditioner and record the operating data.
6. Protect the unit with a fuse of suitable capacity for the maximum input current or with another overload protection device.
7. Ensure that the mains voltage corresponds to that stamped on the rating plate. Keep the switch or power plug clean. Insert the power plug correctly and firmly into the socket, thereby avoiding the risk of electric shock or fire due to insufficient contact.
Do not pull out the plug to switch off the appliance when it is in operation, since this could create a spark and cause a fire, etc.
8. Check that the socket is suitable for the plug, otherwise have the socket changed.
9. The appliance must be equipped with devices capable of disconnect from the mains power supply, have a contact separation in all poles to provide full disconnection under “over voltage category III conditions”, these devices must also be incorporated into the fixed wiring in accordance with the wiring rules.
10. The air conditioner must be installed by professional or qualified technician.
11. Do not install the appliance at a distance of less than 50 cm from inflammable substances (alcohol, etc.) Or from pressurized containers (e.g. spray cans).
12. If the appliance is used in an area without the possibility of ventilation, precautions must be taken to prevent any leaks of refrigerant gas from remaining in the environment and creating a danger of fire.
13. The packaging materials are recyclable and should be disposed of in the separate waste bins. Take the air conditioner at the end of its useful life to a special waste collection center for disposal.
14. Only use the air conditioner as instructed in this booklet. These instructions are not intended to cover any possible condition and situation. As with any electrical household appliance, common sense and caution are therefore always recommended for installation, operation and maintenance.
15. The appliance must be installed in accordance with applicable national regulations. The appliance shall be installed in accordance with national wiring regulations.
16. Before accessing the terminals, all the power circuits must be disconnected from the power supply.
17. This appliance can be used by children aged from 8 years and above and persons with reduced physical, sensory or mental capabilities or lack of experience and knowledge if they have been given supervision or instruction concerning use of the appliance in a safe way and understand the hazards involved. Children shall not play with the appliance. Cleaning and user maintenance shall not be made by children without supervision.

SAFETY PRECAUTIONS

SAFETY RULES AND RECOMMENDATIONS FOR THE INSTALLER

18. Cleaning and maintenance must be carried out by specialized technical personnel. In any case disconnect the appliance from the mains electricity supply before carrying out any cleaning or maintenance.
19. This appliance has been made for air conditioning domestic environments only and must not be used for any other purpose, as drying clothes, cooling food, etc.
20. Always use the appliance with the air filter mounted. Airconditioning without air filter could cause an excessive accumulation of dust and lead inner parts function failure.
21. The user is responsible for having the appliance installed by a qualified technician, who must check that earthing/grounding is done in accordance with current legislation and insert a thermos magnetic circuit breaker.
22. The batteries in the remote controller must be recycled or disposed of properly. For disposal of scrap batteries, please discard the batteries as sorted municipal waste at the accessible collection point.
23. Never remain directly exposed to the flow of cold air for a long time. The direct and prolonged exposition to cold air could be dangerous for your health. Particular care should be taken in the rooms where there are children, old or sick people.
24. If the appliance gives off smoke or there is a smell of burning, immediately cut off the power supply and contact the Service Center.
25. Have repairs carried out only by an authorised Service Centre of Company. Incorrect repair could expose the user to the risk of electric shock, etc.
26. Unhook the automatic switch if you foresee not to use the device for a long time. The airflow direction must be properly adjusted.
27. The flaps must be directed downwards in the heating mode and upwards in the cooling mode.
28. Ensure that the appliance is disconnected from the power supply when it intends to keep inoperative for a long period and before carrying out any cleaning or maintenance.
29. Selecting the most suitable temperature can prevent damage to the appliance.

SAFETY PRECAUTIONS

SAFETY RULES AND PROHIBITIONS

1. Do not bend, tug or compress the power cord since this could damage it. Electrical shock or fire is probably due to a damaged power cord. only Specialized technical personnel can replace a damaged power cord.
2. Do not use extensions or gang modules.
3. Do not touch the appliance when barefoot or parts of the body are wet or damp.
4. Do not obstruct the air inlet or outlet of the indoor or outdoor unit. The obstruction of these openings causes a reduction in the operative efficiency of the conditioner with possible consequent failures or damages.
5. In no way alter the characteristics of the appliance.
6. Do not install the appliance in environments where the air could contain flammable gas, oil or sulphur, or near sources of heat.
7. This appliance is not intended for use by persons (including children) with reduced physical, sensory or mental capabilities, or lack of experience and knowledge, unless they have been given supervision or instruction concerning use of the appliance by a person responsible for their safety.
8. Do not climb onto or place any heavy or hot objects on top of the appliance.
9. Do not leave windows or doors open for long when the air conditioner is operating.
10. Do not direct the airflow onto plants or animals. A long direct exposition to the flow of cold air of the conditioner could have negative effects on plants and animals.
12. Do not put the conditioner in contact with water. The electrical insulation could be damaged and that causing electrocution.
13. Do not climb onto or place any objects on the outdoor unit.
14. Never insert a stick or similar object into the appliance. It could cause injury.
15. Children should be supervised to ensure that they do not play with the appliance. If the supply cord is damaged, it must be replaced by the manufacturer, its service agent or similarly qualified technician to avoid a hazard.

NAME OF PARTS

Indoor Unit

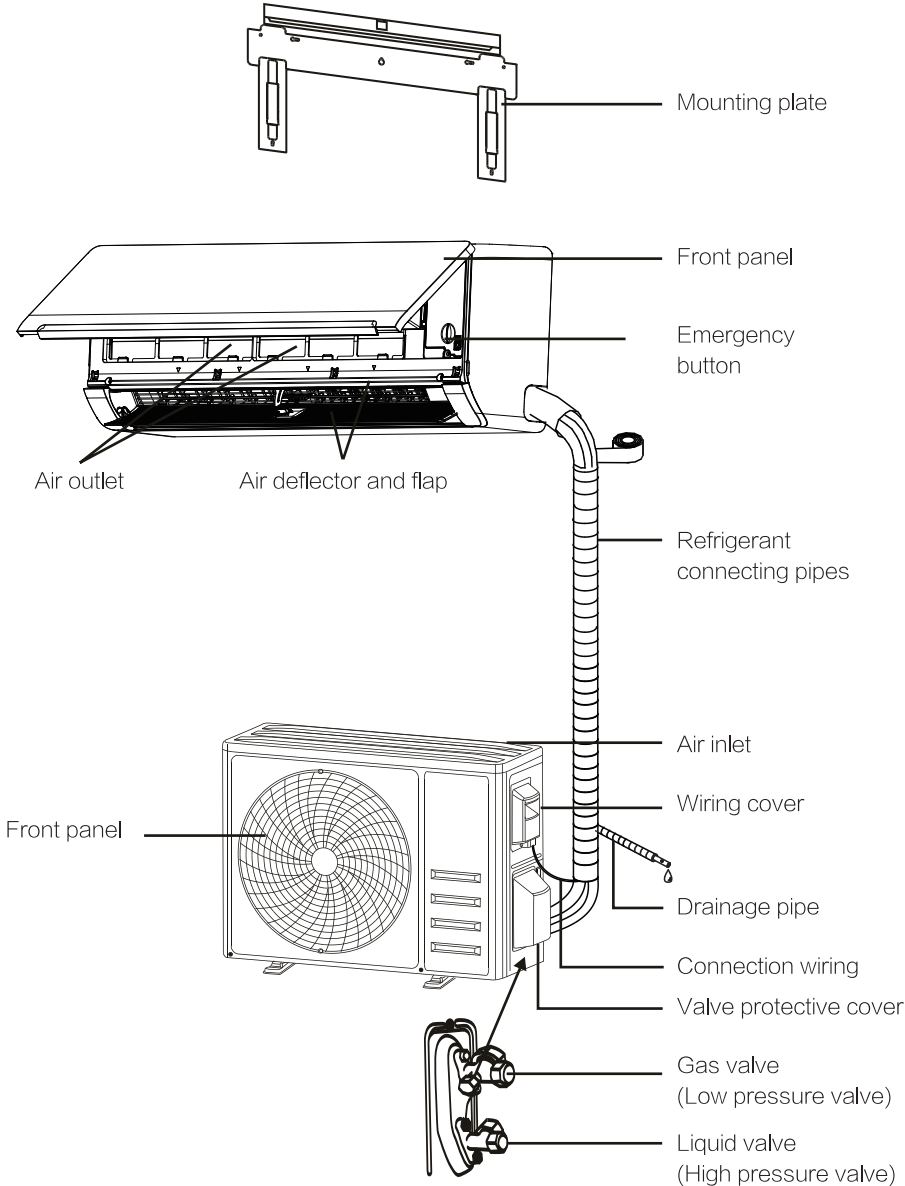



Note: This figure shown may be different from the actual object. Please take the latter as the standard.

NAME OF PARTS

Indoor Display



NO.	LED	Function
1		Indicator for Timer, temperature and Error codes.
2		Lights up during Timer operation.
3		SLEEP mode



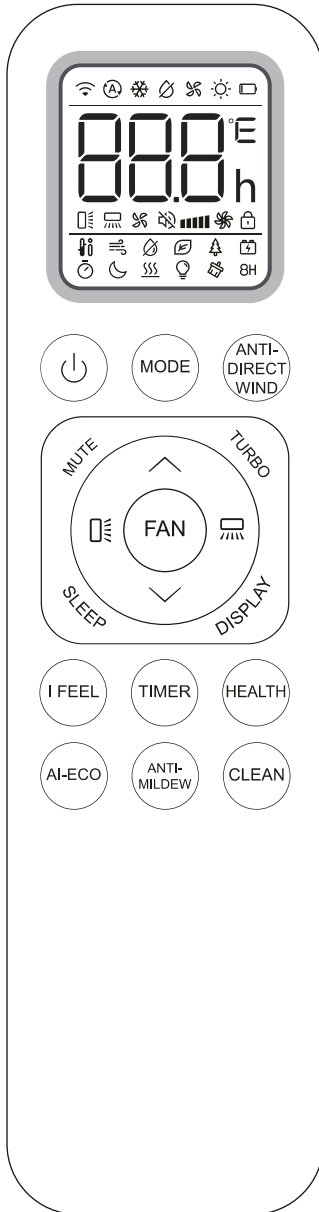

The shape and position of switches and indicators may be different according to the model, but their function is the same.

REMOTE CONTROLLER



REMOTE CONTROLLER

Remote controller buttons

NO.	Button	Function
1		To turn on/off the air conditioner.
2	MODE	To select the mode operation: AUTO, COOL, DRY, FAN, HEAT.
3	TURBO	To activate/deactivate the TURBO function.
4	MUTE	To switch-on/off the MUTE function.
5	AI-ECO	To activate/deactivate the AI Energy Saving function. Long press to activate/deactivate the 8°C heating function (depending on models)
6	SLEEP	To switch-on/off the function SLEEP.
7	DISPLAY	To switch-on/off the LED display.
8	FAN	To select the fan speed of auto/mute/low/low-mid/mid/mid-high/hign/turbo.
9	∧ (TEMP UP)	To increase the temperature or lengthen the time when setting the TIMER.
10	∨ (TEMP DN)	To decrease the temperature or reduce the time when setting the TIMER.
11		To adjust the air flow direction vertically(optional).
12		To adjust the air flow direction horizontally.
13	I FEEL	To activate the function of I FEEL.
14	TIMER	To set the time for timer on/off.
15	HEALTH	To activate/deactivate the HEALTH function(dependent on models).
16	ANTI-DIRECT WIND	To activate/deactivate the ANTI DIRECT WIND function.
17	ANTI-MILDEW	To switch on/off the function ANTI-MILDEW.
18	CLEAN	To activate/deactivate the SELF-CLEAN function(dependent on models).
19	MODE + ∧	To reset WiFi press MODE + ∧ buttons together for more than 3 seconds (depending on models).
20	MODE + ∨	To activate/deactivate the VOICE function, press MODE + ∨ buttons together for more than 3 seconds (depending on models).
21	GEN + ANTI-MILDEW	To memory the setting temperature, setting mode and setting fan speed as you need.
22	GENTLE WIND	To activate the function of GENTLE WIND, press FAN and MUTE buttons together for more than 3 seconds.
23	CHILD-LOCK	To activate the function of Child Lock,press MODE and TIMER buttons together for more than 3 seconds.

 The display and some functions of the remote control may vary according to the model.

 The shape and position of buttons and indicators maybe difference according to the model, but their function is the same.

 The unit confirms the correct reception of each press button with a beep.

 There might some functions not fit for your air conditioner, you will hear a beep when you press these buttons, but air conditioner do not response, we express our apologies.

REMOTE CONTROLLER

Remote controller DISPLAY, meaning of symbols on the liquid crystal display

NO.	Symbols	Meaning
1		AUTO MODE indicator
2		COOLING MODE indicator
3		DRY MODE indicator
4		FAN MODE indicator
5		HEATING MODE indicator
6		BATTERY indicator
7		TEMPERATURE/ CLOCK indicator
8		FLAP SWING (Air flow) indicator
9		MUTE indicator
10		TURBO indicator
11		FAN SPEED indicator
		(FLASH) AUTO FAN indicator
12		CHILD LOCK indicator
13		I FEEL indicator
14		GENTLE WIND indicator (not available in this model)
15		Anti-Mildew indicator
16		ECO indicator
17		HEALTHY indicator (not available in this model)
18		ANTI-DIRECT WIND Function Indicator
19		TIMER indicator
20		SLEEP MODE indicator
21		Auxiliary heating function indicator (not available in this model)
22		DISPLAY LIGHT indicator
23		CLEAN function indicator
24	8H	8°C heating function indicator

REMOTE CONTROLLER

Replacement of Batteries

Remove the battery cover plate from the rear of the remote control, by sliding it in direction as the arrow.

Install the batteries according the direction (+ and -) shown on the Remote Control. Reinstall the battery cover by sliding it into place.

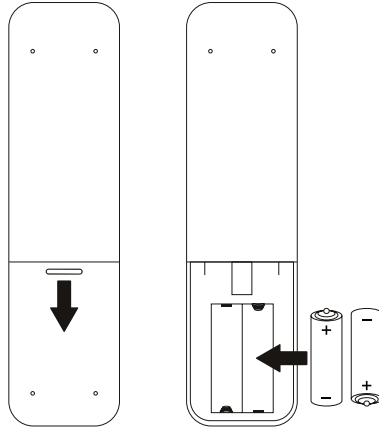

The image is for reference only; please refer to the actual product.

- ⚠
- Use 2 LRO 3 AAA (1.5V) batteries.
- Do not use rechargeable batteries .
- Replace the old batteries with new ones of the same type when the display is no longer legible.
- Do not dispose batteries as unsorted municipal waste.
- Collection of such waste separately for special treatment is necessary.

Recommendations for locating and using the remote controller holder (if present).
The remote controller be kept in a wall-mounted holder.

⚠ For some models of the remote controller, you can program the temperature display between °C and °F.

1. Press and hold the **TURBO** button over 5 seconds to get into the change mode;
2. Press and hold the **TURBO** button, until it switch to °C and °F ;
3. Then release the pressing and wait for 5 seconds, the function will be selected.

Note:

1. Direct the remote control toward the Air conditioner.
2. Check that there are no objects between the remote control and the Signal receptor in the indoor unit.
3. Never leave the remote control exposed to the rays of the sun.
4. Keep the remote control at a distance of at least 1m from the television or other electrical appliances.

REMOTE CONTROLLER

The air sucked by the fan enters from the grill and passes through the filter, then it is cooled/dehumidified or heated through the heat exchanger.

The direction of the air outlet is motorized up and down by flaps, and manually moved right and left by the vertical deflectors, for some models, the vertical deflectors could be controlled by motor as well.

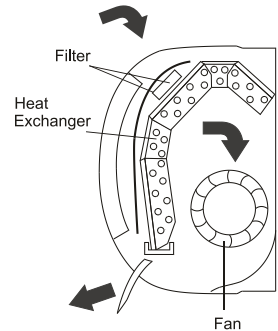

Turn ON / Turn OFF the air conditioner

Press the button  to turn on or turn off the air conditioner.

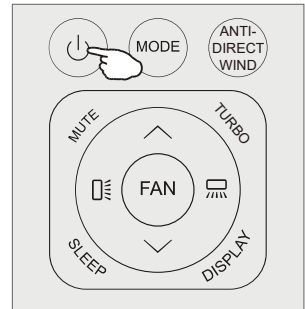



COOLING MODE



The cooling function allows the air conditioner to cool the room and at the same time reduces Air humidity.

To activate the cooling function (COOL), press the **MODE** button until the symbol ❄️ appears on the display.

With the button  or  set a temperature lower than that of the room.

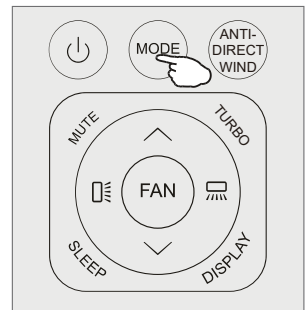

REMOTE CONTROLLER

HEATING MODE



The heating function allows the air conditioner to heat the room.

To activate the heating function (HEAT), press the **MODE** button until the symbol ☀️ appears on the display.

With the button \vee or \wedge set a temperature higher than that of the room.

⚠️ In HEATING operation, the appliance can automatically activate a defrost cycle, which is essential to clean the frost on the condenser so as to recover its heat exchange function. This procedure usually lasts for 2-10 minutes. During defrosting, indoor unit fan stop operation.

After defrosting, it resumes to HEATING mode automatically.

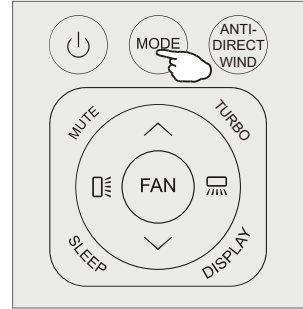

DRY MODE



This function reduces the humidity of the air to make the room more comfortable.

To set the DRY mode, Press **MODE** until ☉ appears in the display. An automatic function of presetting is activated.

FAN MODE(Not FAN button)



Fan mode, air ventilation only.

To set the FAN mode, Press **MODE** until 🌀 appears in the display.

AUTO MODE



Automatic mode.

To set the AUTO mode, press **MODE** until (A) appears on the display.

In AUTO mode the run mode will be set automatically according to the room temperature.

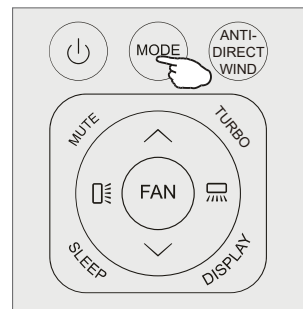

REMOTE CONTROLLER

Change the fan speed

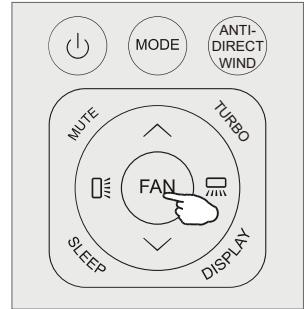

Press **FAN** button to set the running fan speed, it can be set to AUTO/ MUTE/ LOW/ MID-LOW/ MID/ MID-HIGH/HIGH/TURBO speed.

Flashing



AIR FLOW CONTROL

1. Normal 4 way air flow (vertical and horizontal):

- 1) Press  to activate the horizontal flaps to swing from up to down. Press again to stop the swing movement at the current angle.
- 2) Press  to activate the vertical deflectors to swing from left to right. Press again to stop the swing movement at the current angle.(not available)

2. Vector precise air flow

- 1) Press  and hold for 1s, it will go into the horizontal vector air flow, you can select a small swing angle you want:



Stop selection for 5s, press  again, exit the horizontal vector precise air flow.

- 2) Press  and hold for 1s, it will go into the vertical vector air flow:



Stop selection for 5s, press  again, exit the vertical vector precise air flow. (not available)

3. If the vertical deflectors are positioned manually which placed under the flaps, they are allowed to move the air flow direct to rightward or leftward.

⚠ This adjustment must be done while the appliance is switched off.

⚠ Never position "Flaps" manually, the delicate mechanism might get seriously damaged!

⚠ Never poke fingers, sticks or other objects in the air inlet or outlet vents. Such accidental contact with live parts might cause unforeseeable damage or injury.

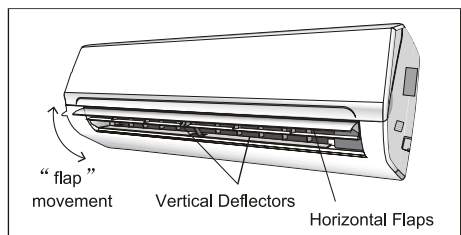
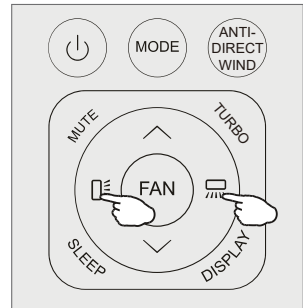

REMOTE CONTROLLER

I FEEL function

I FEEL

Press **I FEEL** button to activate the function, the  will appear on the remote display. Do it again to deactivate this function.

This function enables the remote control to measure the temperature at its current location, and send this signal to the air conditioner to optimize the temperature around you and ensure the comfort.

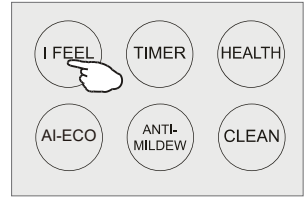

TURBO function



To activate turbo function, press the **TURBO** button, and  will appear on the display. Press again to cancel this function.

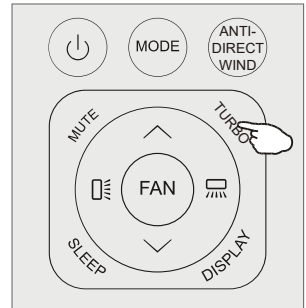

In COOL/HEAT mode, when you select **TURBO** feature, the appliance will operate the fast cooling/fast heating with the highest fan speed.



REMOTE CONTROLLER

ANTI-DIRECT WIND function



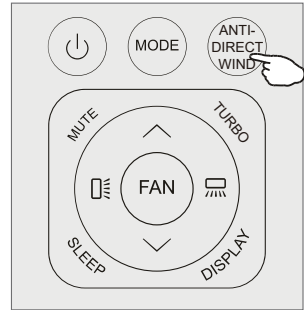

1. Press  button to activate the ANTI-DIRECT WIND function,  will appear on the display. Do it again to deactivate this function.
2. When the ANTI-DIRECT WIND function runs, the horizontal air deflector will only swing in the upper position to prevent air from blowing directly at people.
3. This function is only available in COOLING/DRY mode.



SLEEP MODE



Pre-setting automatic operating program.

- Press  button to activate the sleep mode, and  appears on the display.
- Press and hold  again to cancel this mode.

In sleep mode, the air conditioner will automatically adjust the temperature to make the room more comfortable during the night.

After 10 hours running in sleep mode, the air conditioner will change to the previous setting mode.

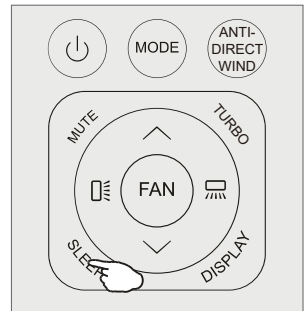

AI Energy Saving Function



1. In Cooling/Heating modes:
Press the  button briefly to activate

the AI Energy Saving function;  will appear on the display. Do it again to deactivate this function.

2. Temperature adjustment rules: Cooling mode: If set temperature $< 26\text{ }^{\circ}\text{C}$, it will automatically adjust to $26\text{ }^{\circ}\text{C}$; if $\geq 26\text{ }^{\circ}\text{C}$, it remains unchanged. Temperature can be adjusted between $16\text{ }^{\circ}\text{C}$ – $31\text{ }^{\circ}\text{C}$ afterward. Heating mode: If set temperature $> 25\text{ }^{\circ}\text{C}$, it will automatically adjust to $25\text{ }^{\circ}\text{C}$; if $\leq 25\text{ }^{\circ}\text{C}$, it remains unchanged. Temperature can be adjusted between $16\text{ }^{\circ}\text{C}$ – $31\text{ }^{\circ}\text{C}$ afterward.
3. In this function, the AC will adopt a stepwise frequency reduction, record operating data, and learn from this data to optimize operating parameters in subsequent use, achieving better energy savings.

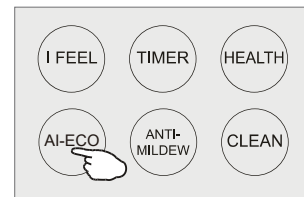

NOTE: The AI Energy Saving Function is available in both COOLING and HEATING modes.

REMOTE CONTROLLER

LED display light ON/OFF

Press **DISPLAY** button to turn on/off the indoor LED display light.

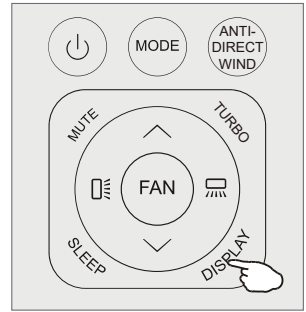

SELF-CLEAN function

1. This function help carry away the accumulated dirt, bacteria, etc from the evaporator.
2. Turn off the air conditioner, press **CLEAN** button to enter this function and it will show "CL" on the display of indoor unit.
3. This function will run about 30 minutes, and it will exit automatically. You will hear 2 beeps when it's finished or cancelled.
4. It's normal if there are some noise during this function process, as plastic materials expand with heat and contract with cold.
5. We suggest operate this function as the following ambient condition to avoid certain safety.

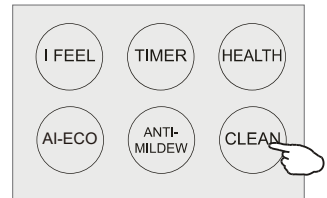

Indoor unit	Temp < 86°F (30°C)
Outdoor unit	41°F (5°C) < Temp < 86°F (30°C)

6. We suggested operate this function once every 3 months.

REMOTE CONTROLLER

TIMER MODE----SET TIMER OFF



To set the air conditioner switching-off automatically.

With the AC on, press the **TIMER** button and then use the \wedge and \vee buttons to set the length of time before the AC will turn off. Press the **TIMER** button again to start the countdown.

Note: To cancel the setted function, press the **TIMER** button again.

Note: In case of power off, it is necessary to set TIMER OFF again.

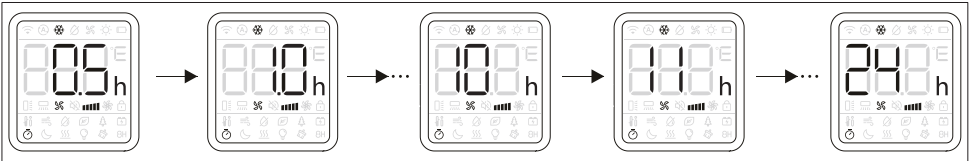

TIMER MODE----SET TIMER ON



To set the air conditioner switching-on automatically.

With the AC off, press the **TIMER** button and then use the \wedge and \vee buttons to set the length of time before the AC will turn on. Press the **TIMER** button again to start the countdown.

When the timer setting was done, you can set the operation mode, fan speed, desired temperature, air flow when air conditioner star to run.

Note: To cancel the timer function, press the **TIMER** button again.

Note: In case of power off, it is necessary to set TIMER ON again.

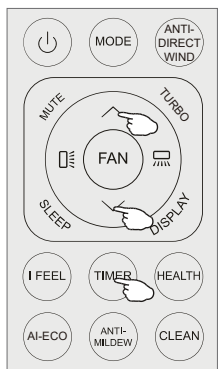

REMOTE CONTROLLER

8°C heating function

8H

1. Long press **ECO** button over 3 seconds to activate this function, and [8°C]([46°F]) will appear on the remote display.
2. This function will auto start the heating mode when the room temperature is lower than 8°C(46°F), and it will return to stand by if the temperature reaches 9°C(48°F).
3. If the room temperature is higher than 18°C(64°F), the appliance will cancel this function automatically.

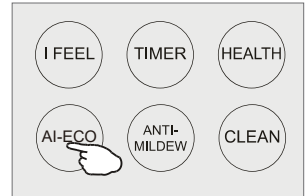

I SET function

Remember your favorite setting and run into it by press One button.

Remember the favorite setting:

1. In each mode (COOLING/ HEATING/ FAN/ DRY), long press **GEN** and **ANTI-MILDEW** buttons over 3 seconds to remember it;
 2. When "AU" flashing appears on the remote controller display, that means the remote controller remember your favorite setting;
- Press any button to quit, and you can reset it by repeat 1, 2 operation.

Run into the favorite setting:

1. In each mode (COOLING/ HEATING/ FAN/ DRY), one press **GEN** and **ANTI-MILDEW** buttons to activate;
2. The appliance will run as your favorite setting and you will see [AU] flashing on the remote controller.
3. Press it again or other buttons to cancel this function.



REMOTE CONTROLLER

MUTE function

MUTE 

1. Press **MUTE** button to activate this function, and  will appear on the remote display. Do it again to deactivate this function.
2. When the MUTE function runs, the indoor unit will operate at lowest fan speed to help experience a quiet feeling.
3. When press **FAN** / **TURBO** button, the MUTE function will be cancel. MUTE function can not be activated under dry mode.

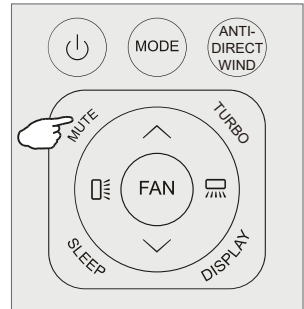

ANTI-MILDEW function

ANTI-MILDEW 

1. Press **ANTI-MILDEW** button to activate the ANTI-MILDEW function,  will appear on the display. Do it again to deactivate this function.
2. After running COOL / DRY for more than 30 minutes, you can operate this function. Then, when the unit is turned off, the unit will blow airflow for about 15 minutes to dry the inner parts to avoid mildew, the fan shuts off the unit.

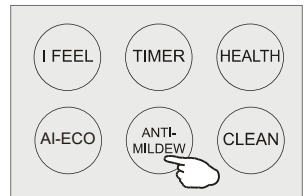

Note: ANTI-MILDEW function only available in DRY/ COOLING mode.

OPERATION INSTRUCTIONS

- ⓘ Attempt to use the air conditioner under the temperature beyond the specified range may cause the air conditioner protection device to start and the air conditioner may fail to operate. Therefore, try to use the air conditioner in the following temperature conditions.

Inverter air conditioner:

MODE Temperature	Heating	Cooling	Dry
Room temperature	0°C~30°C	17°C~32°C	
Outdoor temperature	-20°C~30°C	-15°C~53°C	

With the power supply connected, restart the air conditioner after shutdown, or switch it to other mode during operation, normally the compressor 3-minute delay operation comes into effect.

ⓘ Characteristics of heating operation(Heating pump only)

When the heating function enabled, the indoor unit will take 2~5 minutes for preheating, after that the air conditioner will blow warm air.

Defrosting:

During heating process, if the outdoor unit frosted, the air conditioner will enter to the defrosting operation. During defrosting, the indoor and outdoor fans stop running. The air conditioner will resume heating automatically once defrosting done.

ⓘ Emergency button:

Open the panel and find the emergency button on the electronic control box when the remote controller fails. (Always press the emergency button with insulation material.)

Current status	Operation	Respond	Enter mode
Standby	Single Press the emergency button	It beeps once briefly.	Cooling mode
Standby for Heat pump only	twice Press the emergency button within in 3 seconds	It beeps twice briefly.	Heating mode
Running	single Press the emergency button once	It keeps beeping for a while	Off mode

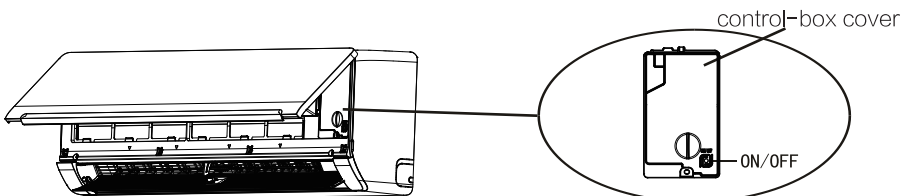

(open the front panel)

INSTRUCTIONS FOR SERVICING(R32)

1. Check the information in this manual to find out the dimensions of space needed for proper installation of the device, including the minimum distances allowed compared to adjacent structures.
2. Appliance shall be installed, operated and stored in a room with a floor area larger than 4m²
3. The installation of pipe-work shall be kept to a minimum.
4. The pipe-work shall be protected from physical damage, and shall not be installed in an unventilated space if the space is smaller than 4m².
5. The compliance with national gas regulations shall be observed.
6. The mechanical connections shall be accessible for maintenance purposes.
7. Follow the instructions given in this manual for handling, installing, cleaning, maintaining and disposing of the refrigerant.
8. Make sure ventilation openings are clear of any obstruction.
9. Notice: The servicing shall be performed only as recommended by the manufacturer.
10. Warning: The appliance shall be stored in a well-ventilated area where the room size corresponds to the room area as specified for operation.
11. Warning: The appliance shall be stored in a room without continuously operating open flames (an operating gas appliance for example) and ignition sources (e.g for example an operating electric heater).
12. The appliance shall be stored so as to prevent mechanical damage from occurring.
13. It is appropriate that anyone who is called upon to work on a refrigerant circuit should hold a valid and up-to-date certificate from an assessment authority accredited by the industry and recognizing their competence to handle refrigerants, in accordance with the assessment specification recognized in the industrial sector concerned. Service operations should only be carried out in accordance with the recommendations of the equipment manufacturer. Maintenance and repair operations that require the assistance of other qualified persons must be conducted under the supervision of the person competent for the use of flammable refrigerants.
14. Every working procedure that affects safety means shall only be carried out by competent persons.

15. Warning:

- * Do not use any means to accelerate the defrosting process or clean the frost on your own. Follow the recommended guidelines from the manufacturer.
- * The appliance shall be stored in a room without continuously operating ignition sources.
- * Be aware that refrigerants may not contain an odor.



Caution: Risk of fire

A2L



Read operator's manual



Operating instructions



Read technical manual

INSTRUCTIONS FOR SERVICING(R32)

16. Information on servicing:

1) Checks to the area

Prior to beginning work on systems containing flammable refrigerants, safety checks are necessary to ensure that the risk of ignition is minimized. For repair to the refrigerating system, the following precautions shall be complied with prior to conducting work on the system.

2) Work procedure

Work shall be undertaken under a controlled procedure so as to minimize the risk of a flammable gas or vapor being present while the work is being performed.

3) General work area

All maintenance staff and others working in the local area shall be instructed on the nature of work being carried out. Work in confined spaces shall be avoided. The area around the workspace shall be sectioned off. Ensure that the conditions within the area have been made safe by control of flammable material

4) Checking for presence of refrigerant

The area shall be checked with an appropriate refrigerant detector prior to and during work, to ensure the technician is aware of potentially flammable atmospheres. Ensure that the leak detection equipment being used is suitable for use with flammable refrigerants, i.e. non-sparking, adequately sealed or intrinsically safe.

5) Presence of fire extinguisher

If any hot work is to be conducted on the refrigeration equipment or any associated parts, appropriate fire extinguishing equipment shall be available to hand. Have a dry powder or CO₂ fire extinguisher adjacent to the charging area.

6) No ignition sources

No person carrying out work in relation to a refrigeration system which involves exposing any pipe work shall use any sources of ignition in such a manner that it may lead to the risk of fire or explosion. All possible ignition sources, including cigarette smoking, should be kept sufficiently far away from the site of installation, repairing, removing and disposal, during which refrigerant can possibly be released to the surrounding space. Prior to work taking place, the area around the equipment is to be surveyed to make sure that there are no flammable hazards or ignition risks. "No Smoking" signs shall be displayed.

7) Ventilated area

Ensure that the area is in the open or that it is adequately ventilated before breaking into the system or conducting any work that will produce heat. A degree of ventilation shall continue during the period that the work is carried out.

The ventilation should safely disperse any released refrigerant and preferably expel it externally into the atmosphere.

8) Checks to the refrigeration equipment

Where electrical components are being changed, they shall be fit for the purpose and to the correct specification. At all times the manufacturer's maintenance and service guidelines shall be followed.

If in doubt consult the manufacturer's technical department for assistance.

INSTRUCTIONS FOR SERVICING(R32)

The following checks shall be applied to installations using flammable refrigerants:

- The charge size is in accordance with the room size within which the refrigerant containing parts are installed;
- The ventilation machinery and outlets are operating adequately and are not obstructed;
- If an indirect refrigerating circuit is being used, the secondary circuit shall be checked for the presence of refrigerant;
- Marking to the equipment continues to be visible and legible. Markings and signs that are illegible shall be corrected;
- Refrigeration pipe or components are installed in a position where they are unlikely to be exposed to any substance which may corrode refrigerant containing components, unless the components are constructed of materials which are inherently resistant to being corroded or are suitably protected against being so corroded.

9) Checks to electrical devices

Repair and maintenance to electrical components shall include initial safety checks and component inspection procedures. If a fault exists that could compromise safety, then no electrical supply shall be connected to the circuit until it is satisfactorily dealt with. If the fault cannot be corrected immediately but it is necessary to continue operation, an adequate temporary solution shall be used. This shall be reported to the owner of the equipment so that all parties are advised.

Initial safety checks shall include:

- The large electrolytic capacitors are discharged: this shall be done in a safe manner to avoid possibility of electric sparking;
- That no live electrical components and wiring are exposed while charging, recovering or purging the system;
- That there is continuity of Reliable earth ground.

17. Repairs to sealed components

- 1) During repairs to sealed components, all electrical supplies shall be disconnected from the equipment being worked upon prior to any removal of sealed covers, etc. If it is absolutely necessary to have an electrical supply to equipment during servicing, then a permanently operating form of leak detection shall be located at the most critical point to warn of a potentially hazardous situation.
- 2) Particular attention shall be paid to the following to ensure that by working on electrical components, the casing is not altered in such a way that the level of protection is affected. This shall include damage to cables, excessive number of connections, terminals not made to original specification, damage to seals, incorrect fitting of glands, etc. Ensure that apparatus is mounted securely. Ensure that seals or sealing materials have not degraded such that they no longer serve the purpose of preventing the ingress of flammable atmospheres. Replacement parts shall be in accordance with the manufacturer's specifications.

NOTE: The use of silicon sealant may inhibit the effectiveness of some types of leak detection equipment. Intrinsically safe components do not have to be isolated prior to working on them.

18. Repair to intrinsically safe components

Do not apply any permanent inductive or capacitance loads to the circuit without ensuring that this will not exceed the permissible voltage and current permitted for the equipment in use. Intrinsically safe components are the only types that can be worked on while live in the presence of a flammable atmosphere. The test apparatus shall be at the correct rating. Replace components only with parts specified by the manufacturer. Other parts may result in the ignition of refrigerant in the atmosphere from a leak.

INSTRUCTIONS FOR SERVICING(R32)

19. Cabling

Check that cabling will not be subject to wear, corrosion, excessive pressure, vibration, sharp edges or any other adverse environmental effects. The check shall also take into account the effects of aging or continual vibration from sources such as compressors or fans.

20. Detection of flammable refrigerants

Under no circumstances shall potential sources of ignition be used in the searching for or detection of refrigerant leaks. A halide torch (or any other detector using a naked flame) shall not be used.

21. Leak detection methods

The following leak detection methods are deemed acceptable for systems containing flammable refrigerants.

Electronic leak detectors shall be used to detect flammable refrigerants, but the sensitivity may not be adequate, or may need re-calibration. (Detection equipment shall be calibrated in a refrigerant-free area). Ensure that the detector is not a potential source of ignition and is suitable for the refrigerant used. Leak detection equipment shall be set at a percentage of the LFL of the refrigerant and shall be calibrated to the refrigerant employed and the appropriate percentage of gas (25 % maximum) is confirmed. Leak detection fluids are suitable for use with most refrigerants but the use of detergents containing chlorine shall be avoided as the chlorine may react with the refrigerant and corrode the copper pipe-work. If a leak is suspected, all naked flames shall be removed/ extinguished. If a leakage of refrigerant is found which requires brazing, all of the refrigerant shall be recovered from the system, or isolated (by means of shut off valves) in a part of the system remote from the leak. Oxygen free nitrogen (OFN) shall then be purged through the system both before and during the brazing process.

22. Removal and evacuation

When breaking into the refrigerant circuit to make repairs or for any other purpose conventional procedures shall be used. However, it is important that best practice is followed since inflammability is a consideration. The following procedure shall be adhered to:

- Remove refrigerant;
- Purge the circuit with inert gas;
- Evacuate;
- Purge again with inert gas;
- Open the circuit by cutting or brazing.

The refrigerant charge shall be recovered into the correct recovery cylinders. The system shall be flushed with OFN to render the unit safe. This process may need to be repeated several times.

Compressed air or oxygen shall not be used for this task.

Flushing shall be achieved by breaking the vacuum in the system with OFN and continuing to fill until the working pressure is achieved, then venting to atmosphere, and finally pulling down to a vacuum. This process shall be repeated until no refrigerant is within the system. When the final OFN charge is used, the system shall be vented down to atmospheric pressure to enable work to take place. This operation is absolutely vital if brazing operations on the pipe-work are to take place. Ensure that the outlet for the vacuum pump is not close to any ignition sources and there is ventilation available.

23. Decommissioning

Before carrying out this procedure, it is essential that the technician is familiar with the equipment. It is recommended good practice that all refrigerants are recovered safely.

Prior to the task being carried out, an oil and refrigerant sample shall be taken in case analysis is required prior to re-use of reclaimed refrigerant. It is essential that electrical power is available before the task is commenced.

INSTRUCTIONS FOR SERVICING(R32)

- a) Isolate system electrically.
- b) Before attempting the procedure, ensure that:
 - . mechanical handling equipment is available, if required, for handling refrigerant cylinders;
 - . all personal protective equipment is available and being used correctly;
 - . the recovery process is supervised at all times by a competent person;
 - . recovery equipment and cylinders conform to the appropriate standards.
- c) Pump down refrigerant system, if possible.
- d) If a vacuum is not possible, make a manifold so that refrigerant can be removed from various parts of the system.
- e) Make sure that the cylinder is situated on the scales before recovery takes place.
- f) Start the recovery machine and operate in accordance with manufacturer's instructions.
- g) Do not overfill cylinders. (No more than 80 % volume liquid charge).
- h) Do not exceed the maximum working pressure of the cylinder, even temporarily.
- i) When the cylinders have been filled correctly and the process completed, make sure that the cylinders and the equipment are removed from site promptly and all isolation valves on the equipment are closed off.
- j) Recovered refrigerant shall not be charged into another refrigeration system unless it has been cleaned and checked.

24. Labeling

For the equipment should be labeled with or without flammable refrigerant.

25. Recovery

When removing refrigerant from a system, either for servicing or decommissioning, it is recommended good practice that refrigerant should be removed safely.

When transferring refrigerant into cylinders, ensure that only appropriate refrigerant recovery cylinders are employed. Ensure that the correct number of cylinders for holding the total system charge are available. All cylinders to be used are designated for the recovered refrigerant and labeled for that refrigerant (i.e. Special cylinders for the recovery of refrigerant). Cylinders shall be complete with pressure-relief valve and associated shut-off valves in good working order.

Empty recovery cylinders are evacuated and, if possible, cooled before recovery occurs. The recovery equipment shall be in good working order with a set of instructions concerning the equipment that in hand and shall be suitable for the recovery of all appropriate refrigerants included, when applicable, flammable refrigerants. In addition, a set of calibrated weighing scales shall be available. Hoses shall be complete with well leak-free disconnect couplings. Before using the recovery machine, check that it is in satisfactory working order, and has been properly maintained, any associated electrical components are sealed to prevent ignition in the event of a refrigerant release. Consult manufacturer if in doubt. The recovered refrigerant shall be returned to the refrigerant supplier in the correct recover cylinder, and the relevant waste transfer note arranged. Do not mix refrigerants in recovery units and especially not in cylinders. If compressors or compressor oils is to be removed, ensure that it has been evacuated to an acceptable level to make certain that flammable refrigerant does not remain within the lubricant.

The evacuation process shall be carried out prior to returning the compressor to the suppliers. Only electric heating to the compressor body shall be employed to accelerate this process. When oil is drained from a system, it shall be carried out safely.

INSTALLATION PRECAUTIONS(R32)

Important Considerations

1. The air conditioner must be installed by professional personnel and the Installation manual is used specially for the professional installer. The installation specifications should be subject to our after-sale service regulations.
2. When filling the combustible refrigerant, any non-standard operation may cause serious injury or injuries to human body and objects.
3. A leak test must be done after the installation completed.
4. It is a must to do the safety inspection before maintaining or repairing an air conditioner with combustible refrigerant to ensure that the fire risk is reduced to minimum.
5. It is necessary to operate the machine under a controlled procedure. Make sure that any risk arising from the combustible gas or vapor during the operation is reduced to minimum.
6. Knows for details of the requirements for the total weight of filled refrigerant and the area of a room to be equipped with an air conditioner (are shown as in the following Tables GG.1 and GG.2)

The maximum charge and the required minimum floor area

$$m_1 = (4 \text{ m}^3) \times \text{LFL}, m_2 = (26 \text{ m}^3) \times \text{LFL}, m_3 = (130 \text{ m}^3) \times \text{LFL}$$

Where LFL is the lower flammable limit in kg/ m³, R32 LFL is 0.306 kg/m³.

For the appliances with a charge amount $m_1 < M = m_2$:

The maximum charge in a room shall be in accordance with the following:

$$m_{\max} = 2.5 \times (\text{LFL})^{(5/4)} \times h_0 \times (A)^{1/2}$$

The required minimum floor area A_{\min} to install an appliance with refrigerant charge M (kg) shall be in accordance with following: $A_{\min} = (M / (2.5 \times (\text{LFL})^{(5/4)} \times h_0))^2$

Where:

Table GG.1 - Maximum charge (kg)

Category	LFL (kg/m ³)	h ₀ (m)	Floor area (m ²)						
			4	7	10	15	20	30	50
R32	0.306	1	1.14	1.51	1.8	2.2	2.54	3.12	4.02
		1.8	2.05	2.71	3.24	3.97	4.58	5.61	7.254
		2.2	2.5	3.31	3.96	4.85	5.6	6.86	8.85

Table GG.2 - Minimum room area (m)

Category	LFL (kg/m ³)	h ₀ (m)	Charge amount (M) (kg)						
			Minimum room area (m ²)						
R32	0.306		1.224kg	1.836kg	2.448kg	3.672kg	4.896kg	6.12kg	7.956kg
		0.6		29	51	116	206	321	543
		1		10	19	42	74	116	196
		1.8		3	6	13	23	36	60
		2.2		2	4	9	15	24	40

Installation Safety Principles



Open Flames Prohibited



Ventilation Necessary



Mind Static Electricity



Must wear protective clothing and anti-static gloves



Don't use mobile phone

INSTALLATION PRECAUTIONS(R32)

3. Installation Safety

- Refrigerant Leak Detector
- Appropriate Installation Location



















The left picture is the schematic diagram of a refrigerant leak detector.

Please note that:

1. The installation site should be well-ventilated.
2. The sites for installing and maintaining an air conditioner using Refrigerant R32 should be free from open fire or welding, smoking, drying oven or any other heat source which temperature higher than 548 °C easily produces open fire.
3. When installing an air conditioner, it is necessary to take appropriate anti-static measures such as wear anti-static clothing and/or gloves.
4. It is necessary to choose the site convenient for installation or maintenance .
The air inlets and outlets of the indoor and outdoor units should be not surrounded by obstacles or close to any heat source or combustible and/or explosive environment.
5. If the indoor unit suffers refrigerant leak during the installation, it is necessary to immediately turn off the valve of the outdoor unit and all the personnel should go out until the refrigerant leaks completely for 15 minutes. If the product is damaged, it is a must to carry such damaged product back to the maintenance station , it is prohibited to welding the refrigerant pipe or conduct other operations on the user's site.
6. It is necessary to avoid the places where there is another electrical product, power switch plug and socket, not to put, bed, sofa or other valuables right under the lines on two sides of the indoor unit.

Suggested Tools

Tool	Picture	Tool	Picture	Tool	Picture
Standard Wrench		Pipe Cutter		Vacuum Pump	
Adjustable/ Crescent Wrench		Screw drivers (Phillips & Flat blade)		Safety Glasses	
Torque Wrench		Manifold and Gauges		Antistatic Gloves	
Hex Keys or Allen Wrenches		Level		Refrigerant Scale	
Drill & Drill Bits		Flaring tool		Mrcron Gauge	
Electric impact drill		Clamp ammeters			

INSTALLATION PRECAUTIONS



Pipe Length and Additional Refrigerant

Inverter Models Capacity (Btu/h)	9K-12K	18K-22K
Length of pipe with standard charge	5m	5m
Maximum distance between indoor and outdoor unit	25m	25m
Additional refrigerant charge	15g/m	25g/m
Max. diff. in level between indoor and outdoor unit	10m	10m
Type of refrigerant	R32	R32

Torque Parameters

PIPE Size	Newton meter [N x m]	Pound-force foot (lbf-ft)	Kilogram-force meter (kgf-m)
1/4 " (ϕ 6.35)	15 - 20	11.1 - 14.8	1.5 - 2.0
3/8 " (ϕ 9.52)	31 - 35	22.9 - 25.8	3.2 - 3.6
1/2 " (ϕ 12)	45 - 50	33.2 - 36.9	4.6 - 5.1
5/8 " (ϕ 15.88)	60 - 65	44.3 - 48.0	6.1 - 6.6

Dedicated Distribution Device and Wire for Air Conditioner

INVERTER TYPE MODEL capacity (Btu/h)		9k	12k	18k	24k
		sectional area			
Power supply cable	N	1.5mm ²	1.5mm ²	1.5mm ²	2.5mm ²
	L	1.5mm ²	1.5mm ²	1.5mm ²	2.5mm ²
		1.5mm ²	1.5mm ²	1.5mm ²	2.5mm ²
Connection cable	N	0.75mm ²	0.75mm ²	0.75mm ²	0.75mm ²
	L or (L)	0.75mm ²	0.75mm ²	0.75mm ²	0.75mm ²
	1	0.75mm ²	0.75mm ²	0.75mm ²	0.75mm ²
		0.75mm ²	0.75mm ²	0.75mm ²	0.75mm ²

 **Note:** The tables for reference only, the equipment installation shall meet the requirements of local laws and regulations.

Note for joints made at the installation site

Joints shall be tested with detection equipment with a capability of 5g/year of refrigerant or better, with the equipment in standstill and under operation or under a pressure of at least these standstill or operation conditions.

INDOOR UNIT INSTALLATION

Step1: Select Installation location

- 1.1 Ensure the installation complies with the equipment performance requirements (defined below) and meets the minimum and maximum connecting piping length and maximum change in elevation as defined in the System Requirements section.
 - 1.2 Air inlet and outlet should be clear of obstructions, ensuring proper airflow throughout the room.
 - 1.3 condensated water can be easily and safely drained.
 - 1.4 All connections can be easily made to outdoor unit.
 - 1.5 Indoor unit is out of reach of children.
 - 1.6 A mounting wall strong enough to withstand four times the full weight and vibration of the unit.
 - 1.7 Filter can be easily accessed for cleaning.
 - 1.8 Leave enough free space to allow access for routine maintenance.
 - 1.9 Install at least 10 ft. (3 m) away from the antenna of TV set or radio. Operation of the air conditioner may interfere with radio or TV reception in areas where reception too weak. An amplifier may be required for the affected device.
 - 1.10 Do not install the unit in a laundry room or by a swimming pool due to the corrosive environment.
- Minimum Indoor Clearances
- 1.11 For ETL certification area, Caution: Mount with the lowest moving parts at least 8 ft. (2.4 m) above floor or grade level.

Minimum Indoor Clearances

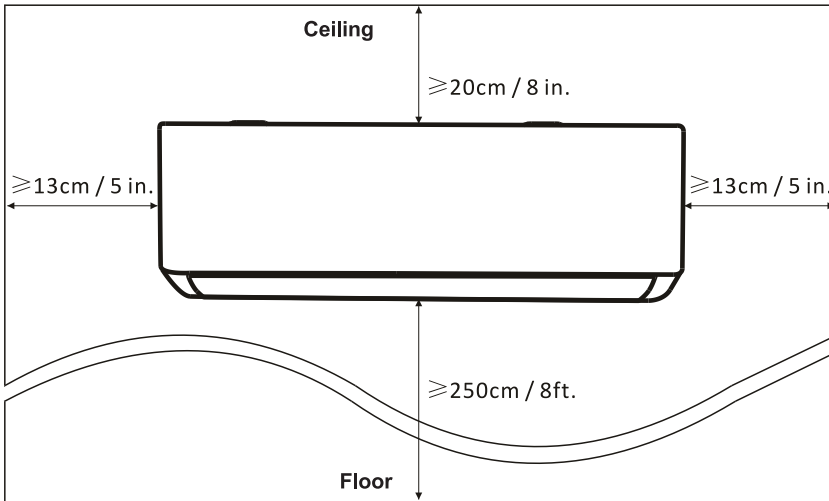

INDOOR UNIT INSTALLATION

Step2: Install Mounting Plate

- 2.1 Take the mounting plate from the back of indoor unit.
- 2.2 Ensure to meet the minimum installation dimension requirements as step 1, according to the size of mounting plate, determine the position and stick the mounting plate close to the wall.
- 2.3 Adjust the mounting plate to a horizontal state with a spirit level, then mark out the screw hole positions on the wall.
- 2.4 Put down the mounting plate and drill holes in the marked positions with drill.
- 2.5 Insert expansion rubber plugs into the holes, then hang the mounting plate and fix it with screws.

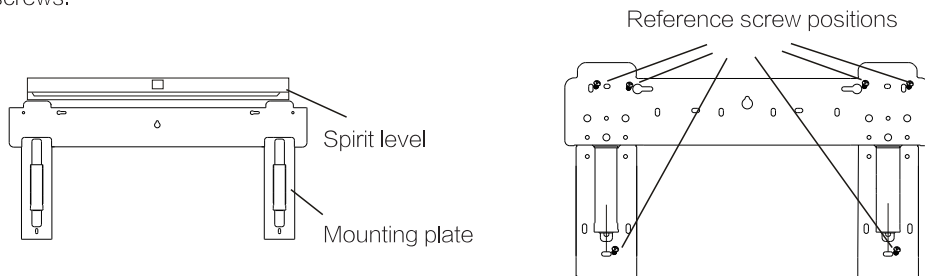

Note:

- (I) Make sure the mounting plate is firm enough and flat against the wall after installation.
- (II) This figure shown may be different from the actual object, please take the latter as the standard.

Step3: Drill Wall Hole

A hole in the wall should be drilled for refrigerant piping ,the drainage pipe, and connecting cables.

- 3.1 Determine the location of wall hole based on the position of mounting plate.
- 3.2 The hole should be have a 70mm diameter at least and a small oblique angle to facilitate drainage.
- 3.3 Drill the wall hole with 70mm core drill and with small oblique angle lower than the indoor end about 5mm to 10mm.
- 3.4 Place the wall sleeve and wall sleeve cover(both are optional parts) to protect the connection parts

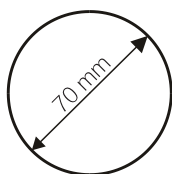

Wall sleeve Cover
(Optional)

Indoor

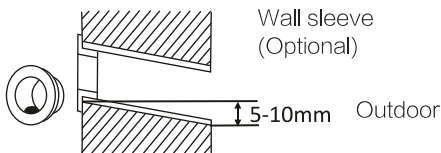

Small oblique angle

INDOOR UNIT INSTALLATION

Step4: Connecting Refrigerant Pipes

4.1 According to the wall hole position, select the appropriate piping mode.

There are three optional piping modes for indoor unit as shown in the figure below:

In Piping Mode 1 or Piping Mode 3, a notch should be made by using scissors to cut the plastic sheet of piping outlet and cable outlet on the corresponding side of the indoor unit.

Note: When cutting off the plastic sheet at the outlet, the cut should be trimmed to smooth.

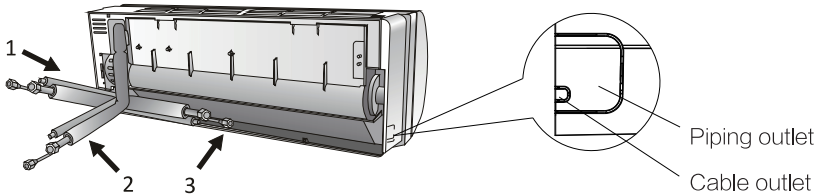

4.2 Bending the connecting pipes with the port facing up as shown in the figure.

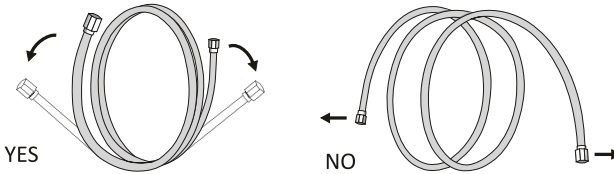

4.3 Take off the plastic cover in the pipe ports and take off the protective cover on the end of piping connectors.

4.4 Check whether there is any sundry on the port of the connecting pipe and make ensure the port is clean.

4.5 After align the center, rotate the nut of the connecting pipe to tighten the nut as tightly as possible by hand.

4.6 Use a torque wrench to tighten it according to the torque values in the torque requirements table;(Refer to the torque requirements table on section **INSTALLATION PRECAUTIONS**)

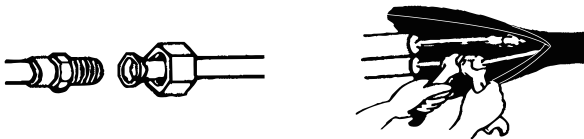

Note: For R32 refrigerant, the connectors should be placed outdoor.

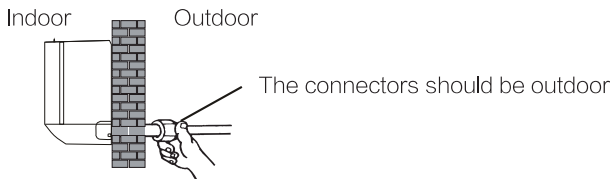

INDOOR UNIT INSTALLATION

Step5: Connect Drainage Hose

5.1 Adjust the drainage hose(if applicable)

In some model, both sides of the indoor unit are provided with drainage ports, you can choose one of them to attach the drainage hose. And plug the unused drain port with the rubber attached in one of the ports.

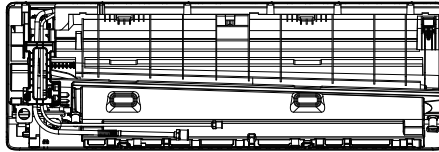

Drainage ports

5.2 Connect the drainage hose to the drainage port, ensure the joint is firm and well sealed.

5.3 Wrap the joint firmly with teflon tape to ensure no water leaks.

Note: Make sure there is no twists or dents, and the pipes should be placed obliquely downward to avoid blockage, to ensure proper drainage.

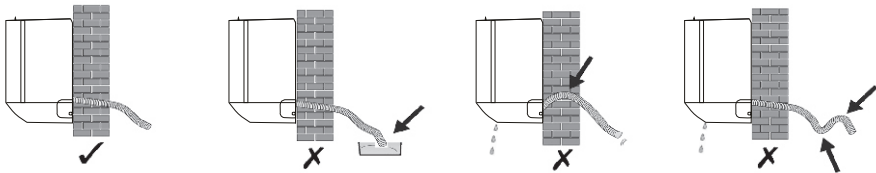

Step6: Connect Wiring

6.1 Choose the right cables size according to the maximum operating current on the name plate.(please refer to section **INSTALLATION PRECAUTIONS**)

6.2 Open the front panel of indoor unit.

6.3 Use a screwdriver, open the electric control box cover, to reveal the terminal block.

6.4 Unscrew the cable clamp.

6.5 Insert one end of the cable into the control box from backside of right end of the indoor unit.

6.6 Connect the wires to corresponding terminal according to the wiring diagram on the electric control box cover. And make sure that they are well connected.

6.7 Screw the cable clamp to fasten the cables.

6.8 Reinstall the electric control box cover and front panel.

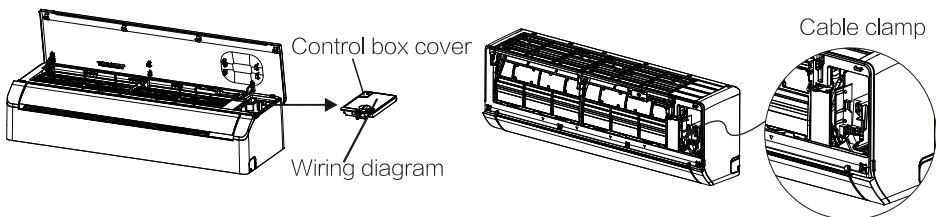

INDOOR UNIT INSTALLATION

Step7: Wrap Piping and Cable

After the refrigerant pipes, connecting wires and drainage hose all installed, bundle them with insulating tape before passing through the wall hole.

7.1 Arrange the pipes ,cables and drainage hose well as the picture.

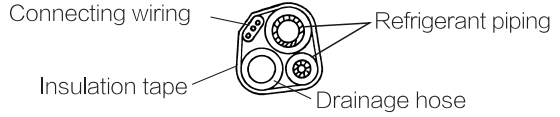

- Note:** (I) Make sure the drainage hose at the bottom always.
(II) Avoid crossing and bending of parts.

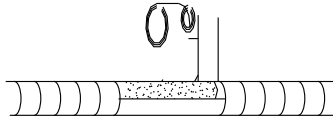

Step8: Mount Indoor Unit

- 8.1 Slowly pass the bundled refrigerant pipes, connecting wires and drainage hose through the wall hole.
- 8.2 Hook the top of indoor unit on the mounting plate.
- 8.3 Apply slight pressure to the left and right sides of the indoor unit, make sure the indoor unit is hooked firmly.
- 8.4 Push down the bottom of indoor unit to let the snaps onto the hooks of the mounting plate, and make sure it hooked firmly.

Sometimes, if the refrigerant pipes were embedded in the wall already, or if you want to connect the pipes and wires on the wall, do as below:

- (I) Grab both ends of the bottom plate, apply a little outward force to take off the bottom plate.
- (II) Hook the top of the indoor unit on the mounting plate without piping and wiring.
- (III) Lift the indoor unit opposite the wall, unfold the bracket on the mounting plate, and use this bracket to prop up the indoor unit, there would be a big space for installation operation.
- (IV) Do the refrigerant piping, wiring, connect drainage hose, and wrap them as Step 4 to 7.
- (V) put the supporting bracket back to the mounting plate.
- (VI) Push down the bottom of indoor unit to let the snaps onto the bottom hooks of the mounting plate, and make sure it firmly hooked .
- (VII) Re-assemble the bottom plate of the indoor unit.

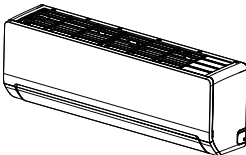

Take off the bottom plate

+

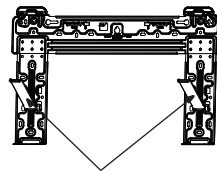

Unfold the bracket on the mounting plate

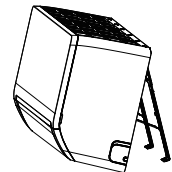

OUTDOOR UNIT INSTALLATION

Step1: Select Installation Location

Select a site that allows for the following:

- 1.1 Do not install the outdoor unit near sources of heat, steam or flammable gas.
- 1.2 Do not install the unit in places too windy or dusty .
- 1.3 Do not install the unit to where people often pass through. Select a place where the air discharge and operating sound will not disturb the neighbors.
- 1.4 Avoid installing the unit to where it would be exposed to direct sunlight (other wise use a protection,if necessary, that should not interfere with the air flow).
- 1.5 Reserve the spaces as shown in the picture for the air to circulate freely.
- 1.6 Install the outdoor unit in a safe and solid place.
- 1.7 If the outdoor unit is subject to vibration, place rubber blankets onto the feet of the unit.

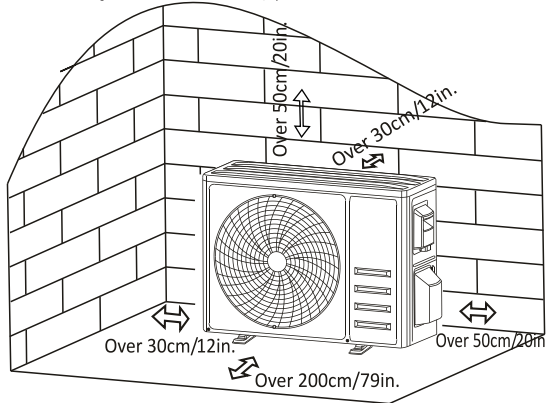

Step2: Install Drainage Hose

- 2.1 This step for heat pump models or RCACs only.
- 2.2 Insert the drainage joint to the hole at the bottom of the outdoor unit.
- 2.3 Connect the drainage hose to the joint and make the connection well enough.

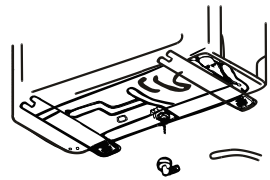

Drainage joint Drainage hose

Step3: Fix Outdoor Unit

- 3.1 According to the outdoor unit installation dimensions to mark the installation position for expansion bolts .
- 3.2 Drill holes and clean the concrete dust and place the bolts .
- 3.3 If applicable install 4 rubber blankets on the hole before place the outdoor unit (Optional).
This will reduce vibrations and noise.
- 3.4 Place the outdoor unit base on the bolts and pre-drilled holes.
- 3.5 Use wrench to fix the outdoor unit firmly with bolts.

Note:

The outdoor unit can be fixed on a wall-mounting bracket. Follow the instruction of the wall-mounting bracket to fix the wall-mounting bracket on the wall, and then fasten the outdoor unit on it and keep it horizontal. The wall-mounting bracket must be able to support at least 4 times of the weight of outdoor unit.

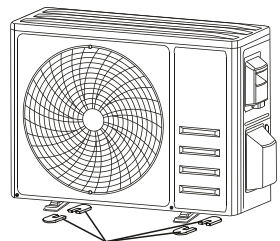

Install 4 rubber blankets (Optional)

OUTDOOR UNIT INSTALLATION

Step4: Install Wiring

- 4.1 Use a phillips screwdriver to unscrew wiring cover, grasp and press it down gently to take it out.
- 4.2 Unscrew the cable clamp and take it down.
- 4.3 According to the wiring diagram pasted inside the wiring cover, connect the connecting wires to the corresponding terminals, and ensure all connections are firmly and securely.
- 4.4 Reinstall the cable clamp and wiring cover.

Note: When connecting the wires of unit, the power supply should be cut off.

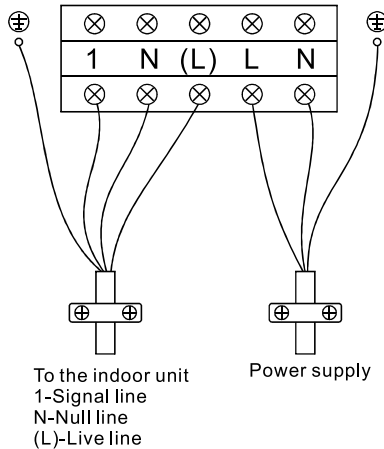
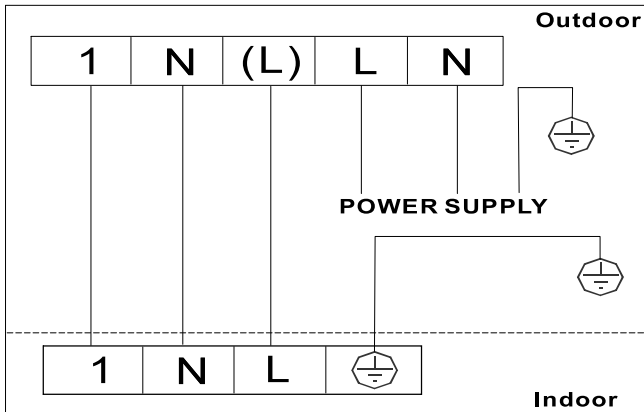
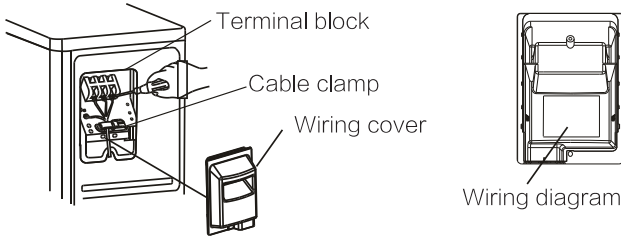

OUTDOOR UNIT INSTALLATION

Step5:Connecting Refrigerant Pipes

- 5.1 Unscrew the valve cover, grasp and press it down gently to take it down(if the valve cover is applicable).
- 5.2 Remove the protective caps from the end of valves.
- 5.3 check whether there is any sundry on the port of the connecting pipe and make ensure the port is clean.
- 5.4 After aligning the center, rotate the flare nut of the connecting pipe to tighten the nut as tightly as possible by hand.
- 5.5 Use a spanner to hold the body of the valve and use a torque wrench to tighten the flare nut according to the torque values in the torque requirements table.
(Refer to the torque specification shown on section **INSTALLATION PRECAUTIONS**)

Always install a minimum of 3 meters of piping to prevent compressor noise, vibrations from being transmitted and to prevent damage to the compressor.

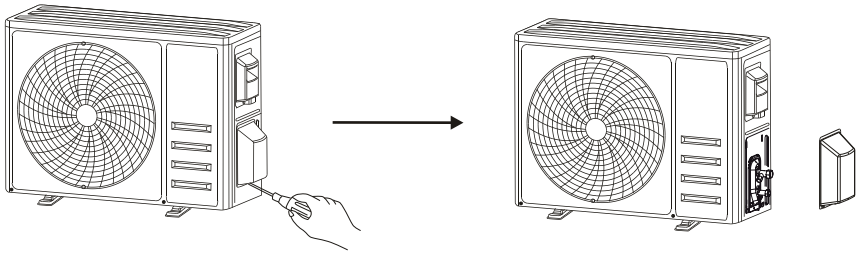

Take down the valve cover

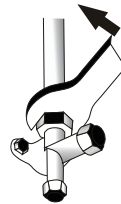
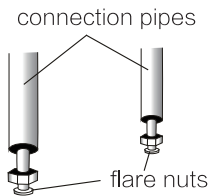

OUTDOOR UNIT INSTALLATION

Step6: Vacuum Pumping

- 6.1 Use a spanner to take down the protective caps from the service port, low pressure valve and high pressure valve of the outdoor unit.
- 6.2 Connect the pressure hose of manifold gauge to the service port on the outdoor unit low pressure valve.
- 6.3 Connect the charge hose from the manifold gauge to the vacuum pump.
- 6.4 Open the low pressure valve of the manifold gauge and close the high pressure valve.
- 6.5 Turn on the vacuum pump to vacuum the system.
- 6.6 The vacuum time should not be less than 15 minutes, or make sure the compound gauge indicates -0.1 MPa (-76 cmHg - 14.5 psi)
- 6.7 Close the low pressure valve of the manifold gauge and turn off the vacuum.
- 6.8 Hold the pressure for 5 minutes, make sure that the rebound of compound gauge pointer does not exceed 0.005 MPa .
- 6.9 Open the low pressure valve counterclockwise for $1/4$ turn with hexagonal wrench to let a little refrigerant fill in the system, and close the low pressure valve after 5 seconds and quickly remove the pressure hose.
- 6.10 Check all indoor and outdoor joints for leakage with soapy water or leak detector.
- 6.11 Fully open the low pressure valve and high pressure valve of the outdoor unit with hexagonal wrench.
- 6.12 Reinstall the protective caps of the service port, low pressure valve and high pressure valve of the outdoor unit.
- 6.13 Reinstall the valve cover.

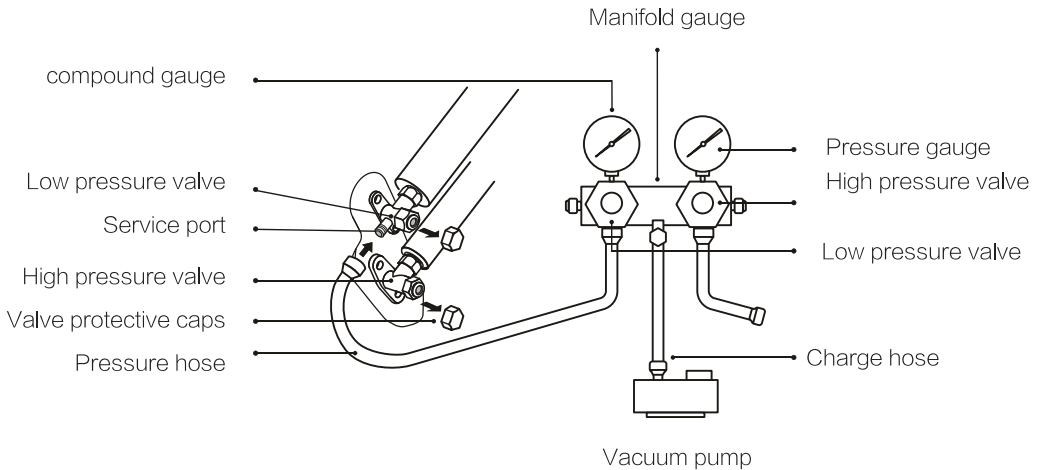

TEST OPERATION

Step6: Vacuum Pumping

Do the following checks before test run.

Description	Inspection method
Electrical safety inspection	<ul style="list-style-type: none">• Check whether the power supply voltage complies with specification.• Check whether there is any wrong or missing connection between the power lines, signal line and earth wires.• Check whether the earth resistance and insulation resistance comply with requirements.
Installation safety inspection	<ul style="list-style-type: none">• Confirm the direction and smoothness of drainage pipe.• Confirm that the joint of refrigerant pipe is installed completely.• Confirm the safety of outdoor unit, mounting plate and indoor unit installation.• Confirm that the valves are fully open.• Confirm that there are no foreign objects or tools left inside the unit.• Complete installation of indoor unit air inlet grille and panel.
Refrigerant leakage detection	<ul style="list-style-type: none">• The piping joint, the connector of the two valves of the outdoor unit, the valve spool, the welding port, etc., where leakage may occur.• Foam detection method: Apply soapy water or foam evenly on the parts where leakage may occur, and observe whether bubbles appear or not, if not, it indicates that the leakage detection result is safe.• Leak detector method: Use a professional leak detector and read the instruction of operation, detect at the position where leakage may occur.• The duration of leak detection for each position should last for 3 minutes or more; If the test result shows that there is leakage, the nut should be tightened and tested again until there is no leakage; After the leak detection completed, wrap the exposed pipe connector of indoor unit with thermal insulation material and wrap with insulation tape.

Test Run Instruction

1. Turn on the power supply.
2. Press the ON/OFF button on the remote controller to turn on the air conditioner.
3. Press the Mode button to switch the mode COOLING and HEATING.
In each mode set as below:
COOLING–Set the lowest temperature
HEATING–Set the highest temperature
4. Run about 8 minutes in each mode and check all functions are properly run and respond the remote controller. Functions check as recommended:
 - 4.1 If the outlet air temperature responds to the cooling and heating modes
 - 4.2 If the water drains properly from the drainage hose
 - 4.3 If the Louver and deflectors(optional) rotate properly



TEST OPERATION

5. Observe the test run state of the air conditioner at least 30 minutes.
6. After the successfully test run, return the normal setting and press ON/OFF button on the remote controller to turn off the unit.
7. Inform the user to read this manual carefully before use, and demonstrate to the user how to use the air conditioner, the necessary knowledge for service and maintenance, and the reminder for storage of accessories.



Note:

If the ambient temperature exceeds the range mentioned in the section OPERATION INSTRUCTIONS and it can not run COOLING or HEATING mode, lift the front panel and refer to the emergency button operation to run the COOLING and HEATING mode.

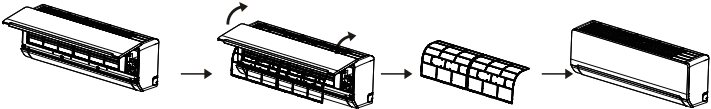
MAINTENANCE

 Warning	<ul style="list-style-type: none"> • When cleaning, you must shut down the machine and cut off the power supply for more than 5 minutes. • Under no circumstances should the air conditioner be flushed with water. • Volatile liquid (e.g. thinner or gasoline) will damage the air conditioner, so only use soft dry cloth or wet cloth dipped with neutral detergent to clean the air conditioner. • Pay attention to cleaning the filter screen regularly to avoid dust covering which will affect the filter screen effect. When the operating environment is dusty, the cleaning frequency should be increased appropriately. • After removing the filter screen, do not touch the fins of the indoor unit to avoid scratching.
Clean the unit	<div style="text-align: center;">  </div> <p style="text-align: center;">Wring it dry and gently wipe the surface of the unit Tip: Wipe frequently to keep air conditioner clean and good appearance .</p>
Disassembly and assembly of filter	<ul style="list-style-type: none"> • Grasp the raised handle on the filter by hand, and then pull the filter out in the direction deviating from the unit, so that the upper edge of the filter is separated from the unit. The filter can be removed by lifting the filter upwards. • When installing the filter, first insert the lower end of the filter screen into the corresponding position of the unit, and then squeeze the upper end of the filter into the corresponding buckling position of the unit body. <p style="text-align: center;">Handle</p> <div style="text-align: center;">  </div>

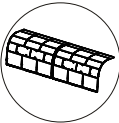
MAINTENANCE

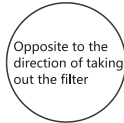
<p>Clean the filter</p>	<div style="display: flex; justify-content: space-around; align-items: center;"> <div style="text-align: center;">  <p>Take out the filter from the unit</p> </div> <div style="text-align: center;">  <p>Clean the filter with soapy water and air dry it</p> </div> <div style="text-align: center;">  <p>Replace the filter</p> </div> </div> <p>Tip: When you find accumulated dust in the filter, please clean the filter in time to ensure the clean, healthy and efficient operation inside the air conditioner.</p>
<p>Service and maintenance</p>	<ul style="list-style-type: none"> • When the air conditioner is not in use for a long time, do the following work: Take out the batteries of the remote controller and disconnect the power supply of the air conditioner. • When starting to use after long-term shutdown: <ol style="list-style-type: none"> 1. Clean the unit and filter screen; 2. Check whether there are obstacles at the air inlet and outlet of indoor and outdoor units; 3. Check whether the drain pipe is unobstructed; <p style="margin-left: 20px;">Install the batteries of the remote controller and check whether the power is on.</p>

TROUBLESHOOTING

MALFUNCTION	POSSIBLE CAUSES
The appliance does not operate	Power failure/plug pulled out.
	Damaged indoor/outdoor unit fan motor.
	Faulty compressor thermomagnetic circuit breaker.
	Faulty protective device or fuses.
	Loose connections or plug pulled out.
	It sometimes stops operating to protect the appliance.
	Voltage higher or lower than the voltage range.
	Active TIMER-ON function.
Damaged electronic control board.	
Strange odor	Dirty air filter.
Noise of running water	Back flow of liquid in the refrigerant circulation.
A fine mist comes from the air outlet	This occurs when the air in the room becomes very cold, for example in the "COOLING" or "DEHUMIDIFYING/DRY" modes.
A strange noise can be heard	This noise is made by the expansion or contraction of the front panel due to variations in temperature and does not indicate a problem.
Insufficient airflow, either hot or cold	Unsuitable temperature setting.
	Obstructed air conditioner intakes and outlets.
	Dirty air filter.
	Fan speed set at minimum.
	Other sources of heat in the room.
No refrigerant.	
The appliance does not respond to commands	Remote control is not close enough to indoor unit.
	The batteries of remote control need to be replaced.
	Obstacles between remote control and signal receiver in indoor unit.
The display is off	Active DISPLAY function.
	Power failure.
Switch off the air conditioner immediately and cut off the power supply in the event of:	Strange noises during operation.
	Faulty electronic control board.
	Faulty fuses or switches.
	Spraying water or objects inside the appliance.
	Overheated cables or plugs.
Very strong smells coming from the appliance.	

TROUBLESHOOTING

ERROR CODE ON THE DISPLAY

In case of error, the display on the indoor unit shown the following error codes:

Display	Description of the trouble
<i>E1</i>	Indoor room temperature sensor fault
<i>E2</i>	Indoor pipe temperature sensor fault
<i>E3</i>	Outdoor pipe temperature sensor fault
<i>E4</i>	Refrigerant system leakage or fault
<i>E6</i>	Malfunction of indoor fan motor
<i>E7</i>	Outdoor ambient temperature sensor fault
<i>E0</i>	Indoor and outdoor communication fault
<i>E8</i>	Outdoor discharge temperature sensor fault
<i>E9</i>	Outdoor IPM module fault
<i>EA</i>	Outdoor current detect fault
<i>EE</i>	Outdoor PCB EEPROM fault
<i>EF</i>	Outdoor fan motor fault
<i>EH</i>	Outdoor suction temperature sensor fault

Note:

The designation "CL" does not indicate an error code; rather, it signifies that the indoor dust filter requires cleaning. To reset the alarm, please disconnect the power supply for 30 seconds before restoring it.

DISPOSAL GUIDELINE (European)

This appliance contains refrigerant and other potentially hazardous materials. When disposing of this appliance, the law requires special collection and treatment. **DO NOT** dispose of this product as household waste or unsorted municipal waste.

When disposing of this appliance, you have the following options:

- Dispose of the appliance at designated municipal electronic waste collection facility.
- When buying a new appliance, the retailer will take back the old appliance free of charge.
- The manufacturer will also take back the old appliance free of charge.
- Sell the appliance to certified scrap metal dealers.
- Disposing of this appliance in the forest or other natural surroundings endangers your health and is bad for the environment. Hazardous substances may leak into the ground water and enter the food chain.



Query mode

Press **@** button to turn on the AC, then hold the remote controller's buttons **G**

and **t2J** for 5 seconds to enter the Query mode. The LCD window will display **00**.

Press "v" or "A" button to select code 00~99, then press MODE to transmit the signal.

Codes	Indoor Display Indication	Rules
00	Cancel the following 01-07 display, Display setting temperature	<ul style="list-style-type: none"> ● If the data on the indoor display is shining means minus "-" or thousands data; eg. "25" and shining means -25 °C ● "A" means 10, B means 11, C means 12, D means 13, E means 14, F means 15; ● Temperature: -40~159 °C; eg. CB and no shining means 125 °C; ● Frequency: 0~159 Hz; eg. BD means 110 Hz; ● Fan speed: 0~2000 rpm, display data = actual data/10, round to tens place; eg. "38" and shining, means 1375~1374 rpm, "77" and no shining, means 765~774 rpm ● EEV data: 0~999 display data = actual data/10, round to tens place; eg. "28" means 275~284. ● Current data: round to ones place; eg. "9" means 8.5A~9.4A; ● Voltage data: display data = actual data/10,
01	Display the indoor environment temperature	
02	Display the indoor pipe temperature	
03	Display the outdoor environment temperature	
04	Display the outdoor pipe temperature	
05	Display the discharge temperature	
06	Display the current (amp)	
07	Display the protection code, if there is error display "--"	
08	Reserved	
09	Reserved	
10	Cancel the following 11-18 display, Display setting temperature	
11	Display the compressor frequency	
12	Display the left indoor fan motor speed	
13	Display the outdoor fan motor speed	
14	Display the current (amp) of compressor	
15	Display the EEV data	
16	Display the AC power voltage	
17	Display the DC power voltage	
18	Display CO ₂ concentration value (display the actual concentration divided by 10)	
19~7g	Reserved	<i>I</i>
79	Auto-start	ON or OF
80	Swing memory	ON or OF
81	Cooling and heating mode	"CC" : Cooling Only, "CH" : Cooling and Heating, "HH" : Heating only
82	The lowest setting temperature	16~25 °C
83	The highest setting temperature	26~31 °C
84	Dry contact delay times	0~6 min
85	Dust filter clean reminder	ON or OF
86	Modbus address	00~FF
87	Cooling temperature compensation	-2~2 °C
89	Heating temperature compensation	-6~6 °C

Dry contact instruction

1. Definition

There is a cable marked DRY CONTACT and with a female blue connector in the end, and there is male cap protect the connector. The cable already connected to the PCB connectors CN29 (GND, DRY, +12V)

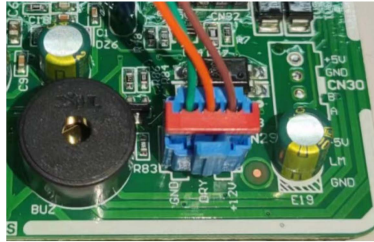
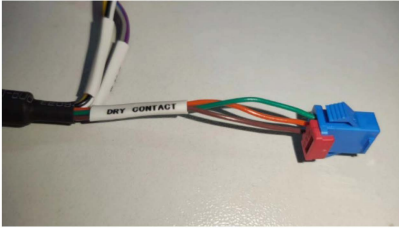

There are 3 wires.

BROWN is voltage +12VDC

ORANGE is ON/OFF input

GREEN is ground (GND)

2. TWO Modes for using the Dry contact.

2.1 Mode 1: Use only contact as dry contact.

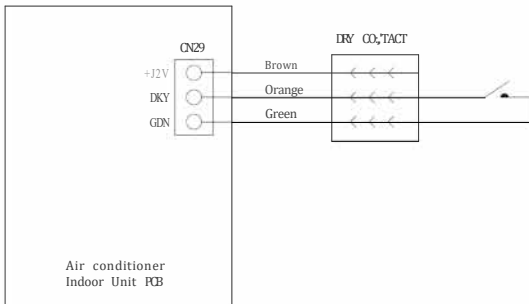

ORANGE is ON/OFF input

GREEN is ground (GND)

When the Switch is "ON", it means the "OFF" signal

When the Switch is "OFF", it means the "ON" signal

In this mode, when receiving OFF signal, the indoor unit will not stop directly, there is a customized time (default 6 mins) delay to prevent start and stop frequently. The Air conditioner will get into the standby mode, when receive the signals from the remote controller, wiring remote controller or emergency button, you will hear 2 beeps and it can't work until receive the ON signal.

Dry contact instruction

2.2 Mode 2: Use contact with 12VDC + relay

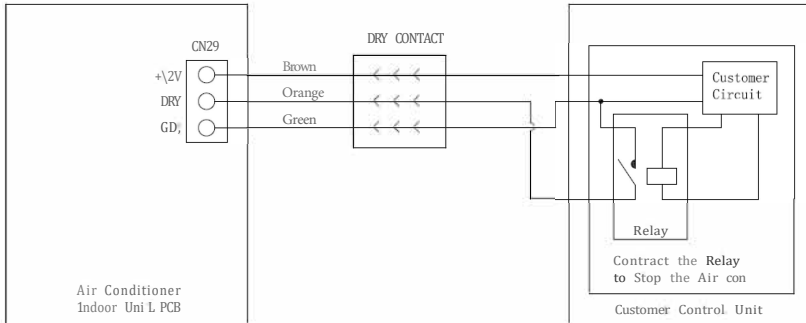

BROWN is voltage 12VDC

ORANGE is ON/OFF input

GREEN is ground (GND)

When the Relay is "ON", it means the "OFF" signal

When the Relay is "OFF", it means the "ON" signal

In this mode, when receiving OFF signal, the indoor unit will not stop directly, there is a there is a customized time (default 6 mins) delay to prevent start and stop frequently. The Air conditioner will get into the standby mode, when receive the signals from the remote controller, wiring remote controller or emergency button, you will hear 2 beeps and it can't work until receive the ON signal.

3. Installation

- 3.1 Cut off the power and open the front panel of indoor unit.
- 3.2 Use a screwdriver, open the electric box cover, and unscrew the cable clamp.
- 3.3 Find the cables marked DRY CONTACT.

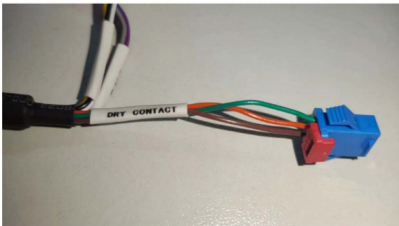

- 3.4 Remove the male cap from the connector of DRY CONTACT.
- 3.5 Take out the cable marked DRY CONTACT from the accessory bag.
- 3.6 Connect the cable.

Dry contact instruction

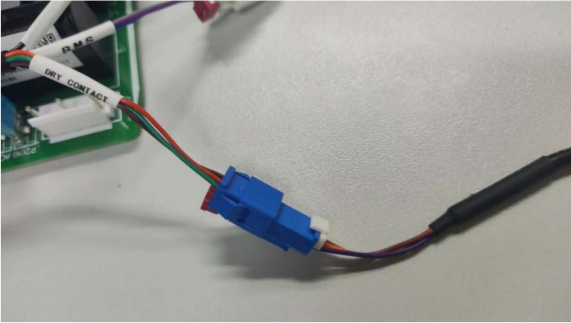

3.7 Screw the cable clamp to fasten the cables.

3.8 Reinstall the electric control box cover and front panel.

3.9 Select the Mode and follow the wiring diagram as mentioned on above item 2 to connect the wirings to end applications.

3.10 Use the remote controller and follow the **"Dry contact delay time setting"** to set the customized time.

dzitsu

EUROFRED
being efficient

Eurofred S.A.
Marqués de Sentmenat 97
08029 Barcelona
www.eurofred.es